

Industrial Communications Guide

Arduino PLC

Raspberry Pi PLC

ESP32 PLC



Industrial Shields®

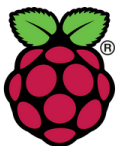

Raspberry Pi



Industrial Communications Guide

This guide shows the industrial communications available in the PLCs based on Open Source CPUs such as Arduino, Raspberry Pi or ESP32.



RS-232



RS-232 (Recommended Standard 232) is a standard for data transmission by serial communication. It formally defines signals connecting between a DTE (Data Terminal Equipment) such as a computer terminal, and a DCE (Data Circuit-Terminating Equipment or Data Communication Equipment), such as a modem or other industrial equipment with this port available.

The standard defines the electrical characteristics and timing of signals, the meaning of signals, and the physical size and pinout of connectors. The current version of the standard is TIA-232-F Interface Between a DTE and a DCE Employing Serial Binary Data Interchange.

The RS-232 standard had been commonly used in computer serial ports and is still widely used in industrial communication devices.

Industrial Shields PLCs include the integrated circuit MAX232

MAX232 converts signals from to TIA-232 (RS-232) serial port to signals suitable for use in TTL-compatible digital logic circuits.



The MAX232 is a dual transmitter/dual receiver used to convert the RX, TX, CTS, RTS signals.



RS-485



RS-485, also known as TIA/EIA-485, is a standard defining the electrical characteristics of drivers and receivers for use in serial communications systems. Electrical signalling is balanced, and multipoint systems are supported.

The standard is published jointly by the Telecommunications Industry Association and Electronic Industries Alliance (TIA/EIA).

Digital communications networks implementing the standard can be used effectively over long distances and in environments with electrical noise.

Multiple receivers may be connected to this network on a multidrop linear bus.

These characteristics make RS-485 useful in industrial control systems and similar applications.

RS-485

Industrial Shields PLCs include the integrated circuit MAX485

It is a low-power and slew-rate-limited transceiver used for RS-485 communication. It works at a single +5V power supply and the rated current is 300 μ A.

Adopting half-duplex communication to implement the function of converting TTL level into RS-485 level, it can achieve a maximum transmission rate of 2.5Mbps.



2.5Mbps

MAX485 transceiver draws supply current of between 120 μ A and 500 μ A under the unloaded or fully loaded conditions when the driver is disabled.

ETHERNET

Ethernet is the most common technology working with the Local Area Networks (LANs) and Wide Area Networks (WANs). The Ethernet communication uses the LAN protocol which is technically known as the IEEE 802.3 protocol.

IEEE 802.3 protocol has evolved and improved over time to transfer data at the speed of one gigabit per second.

Industrial Shields PLCs incorporate the W5500 IC integrated circuit.

The W5500 is a hardwired TCP/IP embedded Ethernet controller that provides an easier Internet connection to the embedded systems. This chip allows users to have Internet connectivity in their applications by using the single chip in which TCP/IP stack, 10/100 Ethernet MAC and PHY are embedded. The W5500 chip incorporates the 32Kb of internal memory buffer for processing Ethernet packet.

With this chip users can implement the Ethernet application by using Socket Programming.

The SPI bus (Serial Peripheral Interface) is provided to facilitate the data transfer with the external microcontroller.

Ethernet uses different protocols to communicate. Some of them are HTTP, HTTPS, MQTT and Modbus protocols.

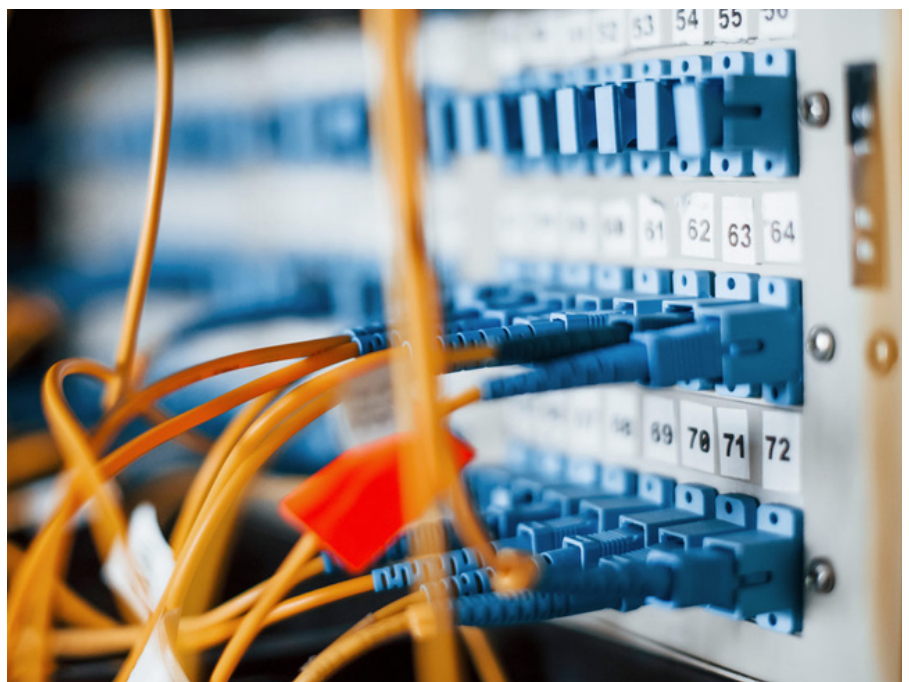

Wi-Fi

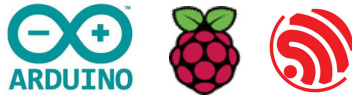

Wi-Fi is simply a trademarked phrase meaning IEEE 802.11x. Wi-Fi works off of the same principle as other wireless devices. It uses radio frequencies to send signals between devices.

To receive the information found on these waves, your radio receiver needs to be set to receive waves of a certain frequency.



In the case of WiFi, this frequency happens to be 2.4GHz and 5GHz.



In an industrial PLC controller Arduino, Wi-Fi uses multiple parts of the IEEE 802 protocol family and is designed to interwork seamlessly with its wired sibling Ethernet.

Compatible devices can be networked via wireless access points to each other, as well as to wired devices and the Internet.

The different versions of Wi-Fi are specified by various IEEE 802.11 protocol standards, with the different radio technologies determining radio bands, and the maximum ranges and speeds that may be achieved.

GPRS / GSM



GPRS (General Packet Radio Services) is a packet-based wireless communication service that promises data rates from 56 up to 114Kbps and a continuous Internet connection for mobile phone and computer users. It works on the mobile network with the help of IP (Internet Protocol) transmissions.

GPRS is the mobile data system behind 2G and some 3G.

56 to 114 Kbps



GPRS is based on Global System for Mobile (GSM) communication and complements existing services such as circuit-switched cellular phone connections and the Short Message Service (SMS).

The Industrial Arduino based PLCs with GPRS are ideal for:

remote monitoring | data logging and remote access | diagnostics and control

by using short text messages (SMS).

You can adjust the messages to be sent from device with **static** (text) or **dynamic** (text and values) content.

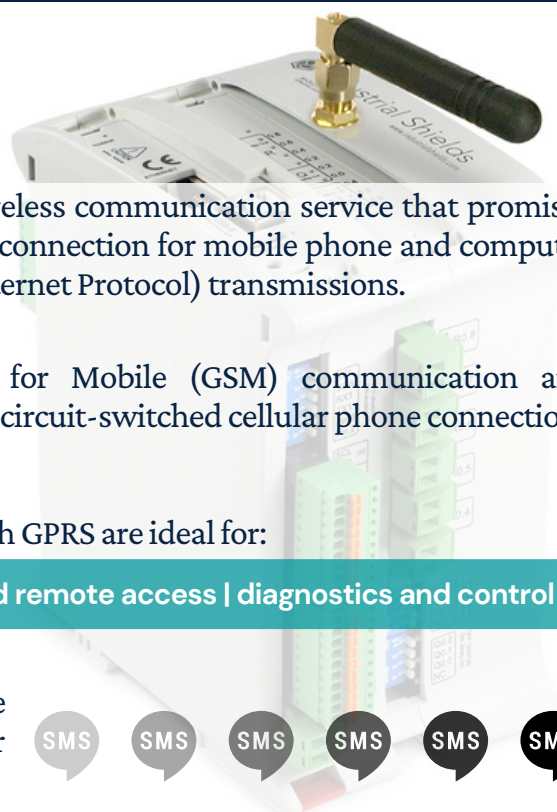

Bluetooth Low Energy

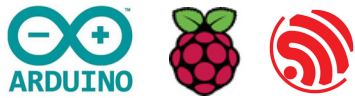

BLE also known as **Bluetooth Low Energy** is based on the TSMC ultra-low-power 40 nm technology, as well as Wi-Fi microchip. The main specs of this kind of Bluetooth are that it is based on the 4.2 BR/EDR dual mode controller version, has +12 dBm transmitting power and a NZIF receiver with a sensitivity of -97 dBm.

The BLE is a subgroup of the 4.0 version with a whole new protocol stack to quickly develop new links. Its objective is to cover applications with low power demand. You can consult more information about these specific versions in the [official webpage](#).



**+12dBm
Transmit**



**-97dBm
Receive**



Some of the Industrial Shields PLCs can use this communication protocol. The Raspberry PLC or the M-Duino and Ardbox range with WiFi and BLE.

In the Arduino based range this feature is using the ESP32 board. The Raspberry Pi PLC range can use this feature directly with the Raspberry Pi board.

Arduino & ESP32 PLC

Both Arduino and ESP32 work with the same module. The integrated WiFi module consists of a single 2.4 GHz Wi-Fi and Bluetooth combo chip designed with the TSMC ultra-low-power 40 nm technology.

It is designed to achieve the best power and RF performance, showing robustness, versatility and reliability in a wide variety of applications and power scenarios.

Some applications are Generic Low-power IoT Sensor Hub, Generic Low-power IoT Data Loggers and Mesh Network. It is designed for Internet-of-Things (IoT) applications.

General Specifications:

- 802.11 b/g/n
- 802.11 n (2.4 GHz), up to 150 Mbps



Up to 150 Mbps



Raspberry PLC

General Specifications:

- 802.11.b/g/n/ac
- 802.11 n (2.4 GHz / 5GHz)
- 5.0 BLE

I2C

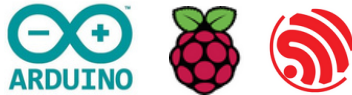

I2C (Inter-Integrated Circuit), pronounced I-squared-C, is a synchronous, multi-master, multi-slave, packet switched, single-ended, serial computer bus. It is widely used to connect lower-speed peripheral ICs to processors and microcontrollers in short-distance, intra-board communications.

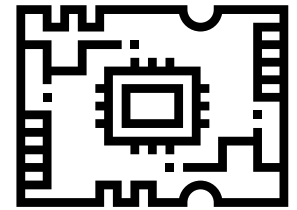

The I2C has gradually been adopted by other manufacturers until becoming a market standard. The I2C bus requires only two cables for operation, one for the clock signal (CLK) and the other for data transmission (SDA), which is an advantage over the SPI bus. By cons, its operation is a little more complex, as well as the electronics needed to implement it.

Data is transferred bit by bit along a single cable (the SDA line). With I2C multiple slaves can be connected to a single master, and multiple masters can be controlled by one or more slaves. This is really useful when you want to have more than one microcontroller recording the data on a single memory card or displaying text on a single LCD screen. It only uses two wires to transmit data between devices:

SDA (Serial Data) – The line for the master and slave to send and receive data.
SCL (Serial Clock) – The line that carries the clock signal.

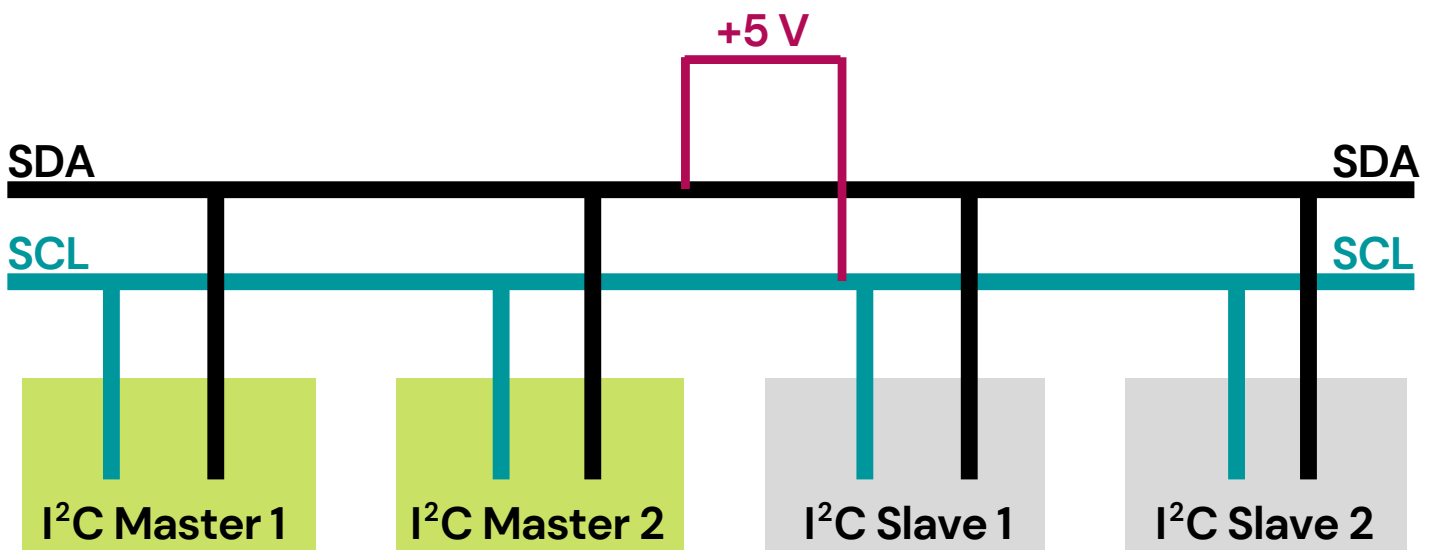

SPI

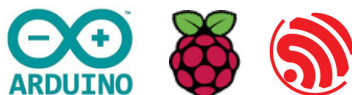

SPI (Serial Peripheral Interface) is an interface bus commonly used to send data between microcontrollers and small peripherals such as shift registers, sensors and SD cards. It uses separate clock and data lines, along with a select line to choose the device you want to talk to.

The SPI bus, which operates at full duplex (i.e. the signals carrying data can go in both directions simultaneously), is a synchronous type data link setup with a Master-Slave interface and can support up to 10Mbps of speed.

Full Duplex

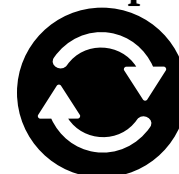

Up to 10 Mbps

Both single-master and multi-master protocols can be used as SPI.

SERIAL TTL

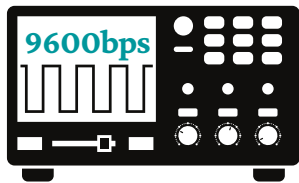

Serial TTL (UART): UARTs (Universal Asynchronous Receivers/Transmitters) transmit one bit at a time at a specified data rate (9600bps usually). This method of serial communication is sometimes called TTL serial (transistor-transistor logic).

Serial communication at TTL level will always remain between the limits of 0V and Vcc, which is often 5V or 3.3V. It is based in two unidirectional channels; Tx to transmit and Rx to receive.

LoRa



LoRa (Long Range) is a low-power wide-area network (LPWAN) protocol developed by Semtech© that uses its own frequency modulation to communicate. This technology is based on a spread spectrum modulation technique derived from Chirp Spread Spectrum (CSS) which is historically used in military and space operations.

LoRa (Long Range modulation) is a type of wireless technology. It uses a radio frequency network modulation such as AM, FM or PSK, but this was created by an important radio chip manufacturer called Semtech©, but now managed by LoRa Alliance©. This modulation is named CSS (Chirp Spread Spectrum) and has been used in military operations for many years. The benefits of this kind of communications are that it can reach long distance (cover wide areas, usually kilometers) and has a good resistance to interferences.

It can reach long distances from 10 to 20 Km.

LoRa is specially useful for long distance communications and for IoT networks such as Smart Cities or agricultural holdings. LoRa communication has a high tolerance to the interferences and a huge sensibility to receive data.

Depending on the zone, it will work on a different frequency

868 MHz on Europa

915 MHz on América

433 MHz on Asia.

It is an ideal option when we need long range communication and IoT networks composed of sensors which are not connected to the electrical network because of its locations or its main usage. For exemple, this communication is widely used in Smart Cities or low coverage areas such as farming applications or networks of sensors/actuators which can take profit of their main characteristics.

Industrial Shields PLCs incorporate the RFM95C integrated circuit.

In the **M-Duino**, RFM95C controller communicates with the Mega board via an SPI bus (Reset is Arduino Mega pin 2, SS is Arduino Mega pin 12, interruption is Arduino Mega pin 13).

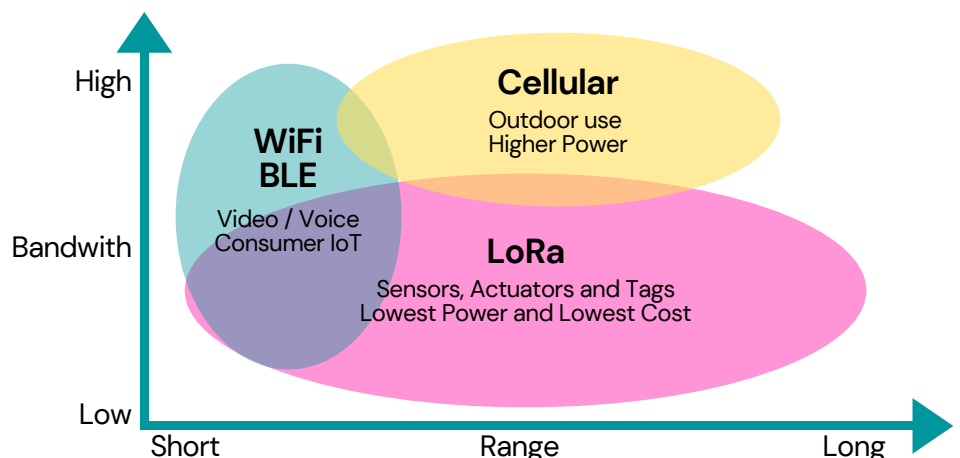

DALI

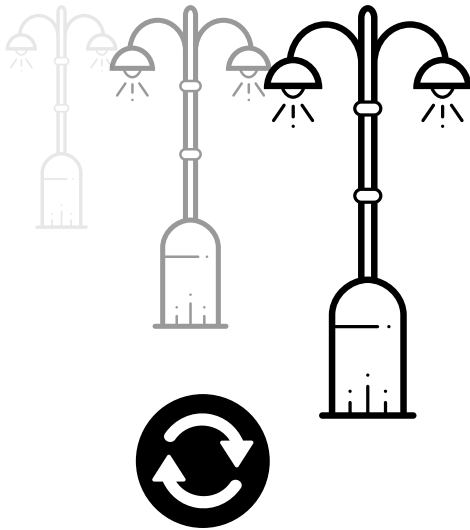

Bidirectional

The Digital Addressable Lighting Interface (DALI) is a communication protocol designed to control light and regulate lighting systems.

It is based on an electronic system that allows you to talk bidirectionally with the connected devices, sending or receiving information. It will be very useful for controlling large lighting systems and regulating their use together with light, motion or timer sensors, allowing the automated control needed for large buildings and companies interested in industrial automation.

1 DALI bus 64 devices

The DALI protocol allows a total of 64 devices to be controlled, interconnected by a DALI Bus.



The main advantages over its competitors would be easy planning and installation together with maximum flexibility when making modifications. Slave devices can be added later and, moreover, they do not need to be assigned to an initial configuration at the time of installation, as everything will be controlled digitally. As no special wiring or accessories are required, it makes the DALI protocol quick and easy to implement.

Thanks to the possibility of regulating the lights automatically, it will be possible to meet time requirements according to energy peaks, sunshine hours or energy rates. The DALI protocol allows the professional control of various environments and configurations such as System Automation or Regulation of lights intensities.

RTC



A real-time clock (RTC) is an electronic device which measures the passage of time and that is usually included in an integrated circuit. RTCs are present in almost any electronic device which needs to keep accurate time. RTCs are devices widely used in electronics. They are also very common in embedded systems and, in general, in a multitude of devices that require time registration.



The RTC devices have an integrated crystal oscillator working at a frequency of 32.7 KHz used for take control of the time. One advantage of the real-time clock is that it uses our ways of measuring time, working with the sexagesimal system.

Industrial Shields PLC uses the DS3231 chip for implementing the real-time clock

This chip has the advantage of incorporating a temperature measurement and compensation guaranteeing an accuracy of at least 2ppm.

CANBus



CAN (Controller Area Network) Bus is, as its name suggests, an automotive bus that allows to the microcontrollers and other devices to communicate to each other without having a host computer. The CAN Bus protocol was developed by Bosch© especially for automotive applications but nowadays is widely used in other areas. It connects individual sensors and systems as an alternative to conventional multi-wire looms.



- **The CAN bus is implemented in Industrial Shields Raspberry PLCs using the MCP2561-E chip to make the conversion between de CAN and Serial, and the MCP2515-I to connect the serial to the SPI.**

This communication follows a specific protocol; CAN Bus uses only two wires for the communication. One is called CAN High and the other is named CAN Low. The CAN controller is connected to all network components through these two wires. Each network node has an individual identifier. All the devices, also called ECU's (Electronic Control Units) are distributed in parallel so that all the nodes receive all the information on the channel each time that is sent. The node only responds when it detects its own identifier. Because of this, the individual nodes can be deleted from the network and the others will not be affected.

The working method is that, when the CAN Bus is in idle mode, both lines transport 2.5V. When data bits are transmitted, the CAN High carries 3.75V and the CAN Low 1.25V, creating a 2.5 differential between two lines. Each line is referenced to the other, not to the Ground, so CAN Bus cannot be affected by inductive peaks, electrical fields or other noise.

It is a reliable communication method.

The CAN can be supplied through the CAN Bus or an external power supply. Another important factor is that all the modules can transmit and receive information from the bus and, as we have said, the data sent by one device will be received by all the others. It is important that the bandwidth of the bus is assigned first to the critical systems. Therefore, the nodes will be organised by priority.

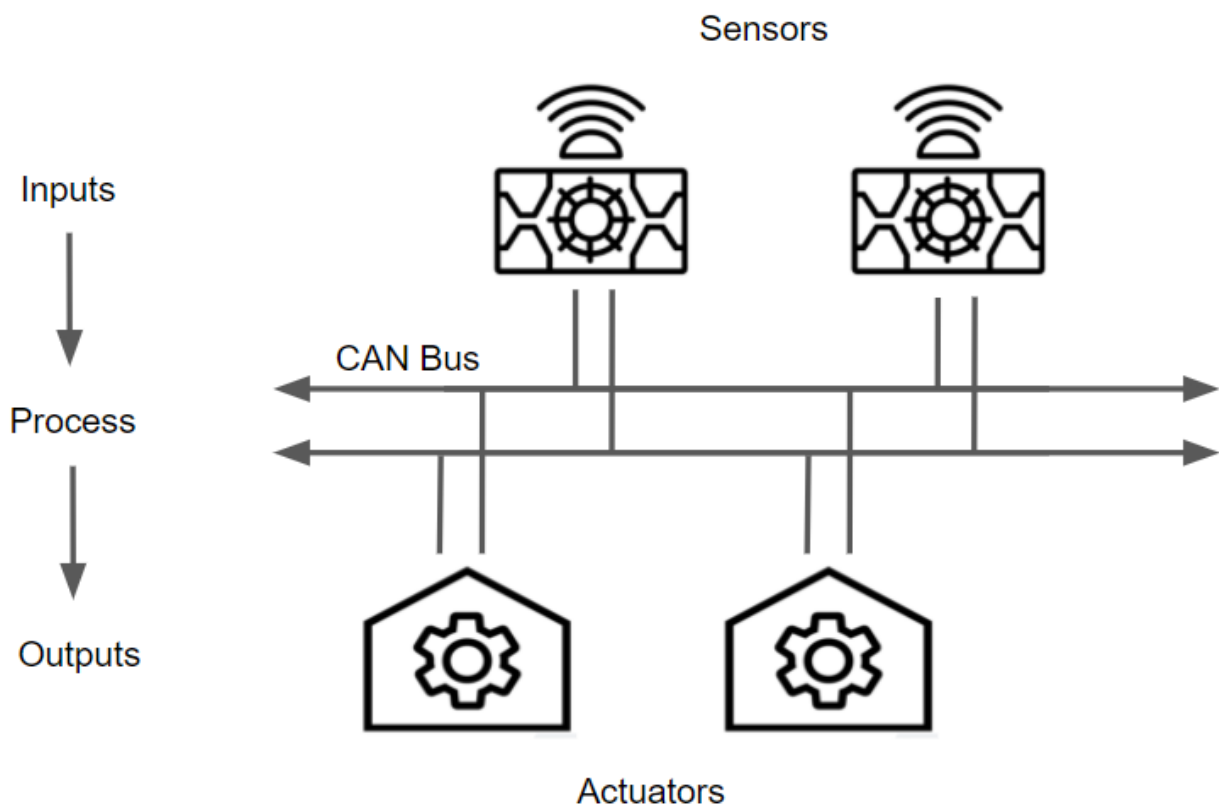

Benefits of using Arduino, Raspberry Pi or ESP32 controllers

Direct Impact on Costs

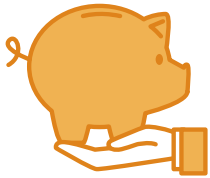

Different platforms can be used to program Arduino-based equipment, most of which are free of cost.

No license fees!



Arduino IDE, the original Arduino and the main one in the market for programming Arduino boards, and therefore Industrial Shields PLCs, is free to download.

<https://www.arduino.cc/en/main/software>



✓ Quantity and quality of inputs and outputs



The range of industrial PLCs based on Arduino, Raspberry Pi or ESP32, complete a range of multiple features in terms of types and quantities of inputs and outputs. There are countless applications in which these controllers can be used, be it for **monitoring, control or automation solutions**.

In addition, there is the possibility of installation in master-slave mode, which greatly increases the number of inputs and outputs available.

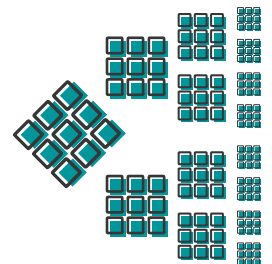

☰ Standard industrial communications, and more

In industrial environments, standard communications are required to facilitate the connection between all kinds of solutions, hardware or software, in the fastest, cheapest, safest and most reliable way. Industrial Shields PLCs have these requirements, although there may be manufacturers or sectors with specific solutions.

I2C SPI	Serial TTL (UART) Ethernet	Wi-Fi & BLE GPRS / GSM	RS485 Half / Full Duplex RS232	LoRa CANBus
------------	-------------------------------	---------------------------	-----------------------------------	----------------

...and more

Thanks to our flexibility we have added to our range of products, specific solutions that our clients have demanded, such as:



Long Range (LoRa), an ideal technology for long distance connections and for IoT networks where sensors that do not have mains electricity are required.



DALI, a protocol created to control lighting systems (Digital Addressable Lighting Interface = Interface Digital de Iluminación Direccional).

Conclusion



The benefits of the different ranges of PLC, with the particularities of each CPU, the number of inputs and outputs, or specific accessories such as GPRS, WiFi, LoRa or DALI, ensure a range of possibilities. With rare exceptions where the specifications of the solution are going to be very exclusive, Industrial Shields PLCs are a great solution for industrial applications in all sectors, whether for automation, monitoring or control.

Do you need more information?



Contact us, let's get in touch

Our **commercial, technical and support team** will assist you by phone, email, skype; or by using the ticket system or chatting directly in our website.

Get in touch with us. We are here, glad to help and support you.



Camí del Grau, 25
Sant Fruitós de Bages 08272 (Barcelona)
Spain



industrialshields@industrialshields.com



Tel: (+34) 938 760 191



<https://www.industrialshields.com>